

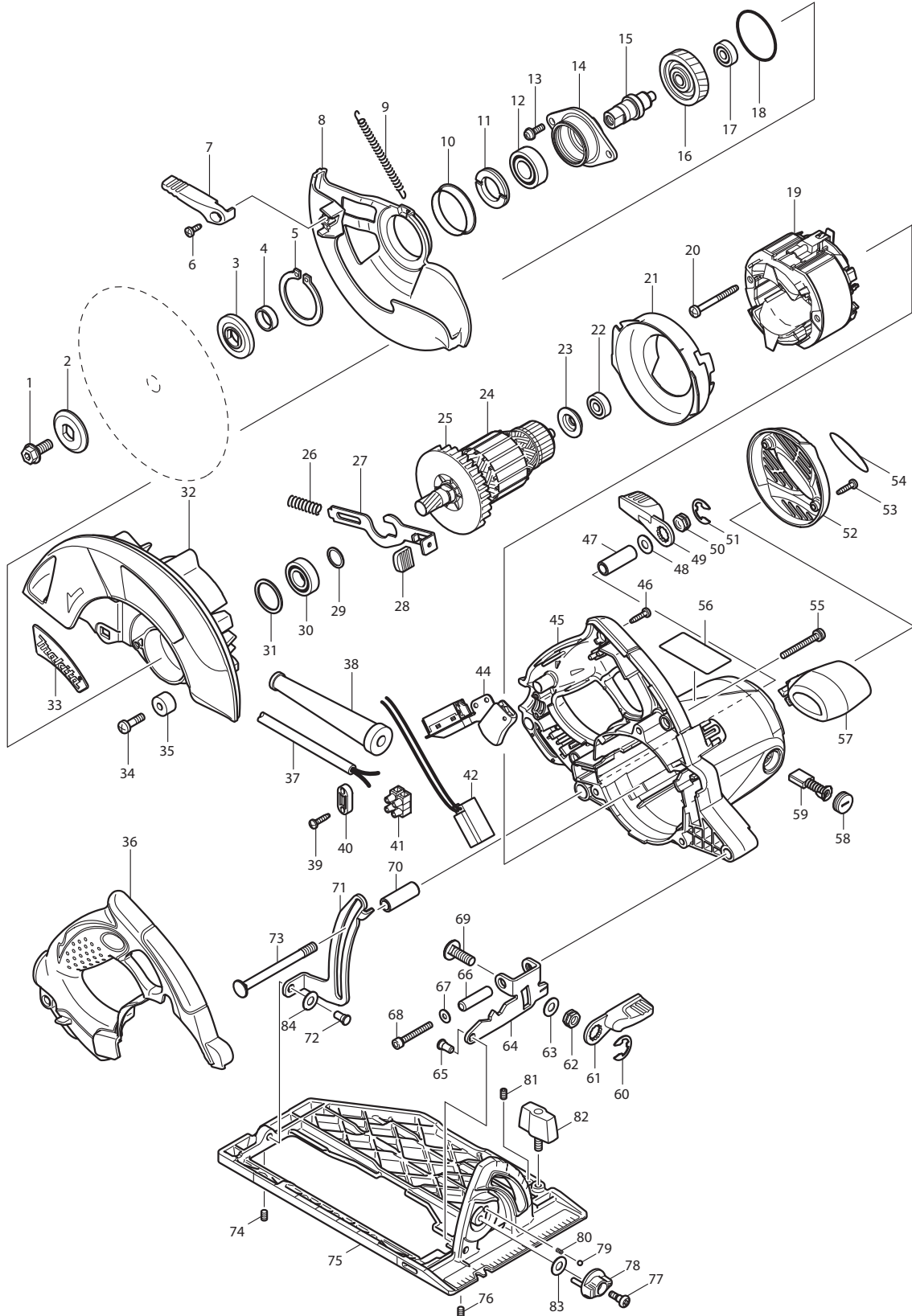

11-2009
5007MGA
7-1/4" CIRCULAR SAW, AC, W/BRAKE



PARTS LIST

Item No	Type	Part No	Description	Qty	Unit
001		266283-4	HEX. SOCKET HEX. BOLT M8X20	1	PC.
002	2	224409-4	* OUTER FLANGE 35	1	PC.
003	2	224411-7	* INNER FLANGE 35	1	PC.
004		257279-6	RING 17	1	PC.
005		961201-4	RETAINING RING S-42	1	PC.
006		266398-7	TAPPING SCREW BIND CT 4X12	1	PC.
007		272252-5	LEVER 65	1	PC.
008	3	319780-0	SAFETY COVER	1	PC.
009		231839-2	TENSION SPRING 4	1	PC.
010	1	345422-0	SPACER	1	PC.
010	2	346880-3	SPACER	1	PC.
011		285848-3	BEARING RETAINER 23-36	1	PC.
012	2	210301-0	BALL BEARING 6003DDW	1	PC.
013		911223-4	PAN HEAD SCREW M5X16	2	PC.
014		318056-2	BEARING BOX	1	PC.
015		324690-8	SPINDLE	1	PC.
016		226630-1	HELICAL GEAR 47	1	PC.
017	2	211031-6	BALL BEARING 608LLB	1	PC.
018		213623-7	O RING 46	1	PC.
019		596291-4	FIELD ASS'Y 115V	1	PC.
019	INC.	654020-2	RING TERMINAL	1	PC.
019	INC.	654502-4	CONNECTOR P-2	1	PC.
020		266397-9	TAPPING SCREW BIND 5X50	2	PC.
021		419548-5	BAFFLE PLATE	1	PC.
022	2	211031-6	BALL BEARING 608LLB	1	PC.
023		681625-5	INSULATION WASHER	1	PC.
024		516976-6	ARMATURE ASS'Y 115V	1	PC.
024	INC.		Item No. 22,23,25,29,30		
025		240003-4	FAN 80	1	PC.
026		231297-2	COMPRESSION SPRING 9	1	PC.
027		345717-1	SHAFT LOCK	1	PC.
028		286275-7	CAP	1	PC.
029		267280-3	FLAT WASHER 15	1	PC.
030		211236-8	BALL BEARING 6002DDW	1	PC.
031		261132-0	URETHANE WASHER 26	1	PC.
032	3	183L20-2	BLADE CASE SET	1	PC.
032	3	INC. 263002-9	RUBBER PIN 4	2	PC.
032	3	INC. 816845-4	SCALE PLATE	1	PC.

Item No	Type	Part No	Description	Qty	Unit
032	3	INC.	Item No. 33		
033		819234-2	MAKITA LOGO PLATE	1	PC.
034		251247-1	+ PAN HEAD SCREW M6X20	1	PC.
035	2	262502-6	RUBBER SLEEVE 6	1	PC.
036		419553-2	HANDLE COVER	1	PC.
037		551187-6	CORD W/PLUG,GUARD 2P-14-2.6M,SJ	1	PC.
037		INC.	Item No. 38		
038		682564-2	CORD GUARD	1	PC.
039		266326-2	TAPPING SCREW 4X18	2	PC.
040		687124-5	STRAIN RELIEF	1	PC.
041		654531-7	TERMINAL BLOCK 2P	1	PC.
042		631709-9	LIGHT CIRCUIT	1	PC.
044	2	651062-7	SWITCH TG933TNB-2	1	PC.
045	1	158099-0	* MOTOR HOUSING COMPLETE	1	PC.
045	1	INC. 643653-8	* BRUSH HOLDER 6.5-13.5	2	PC.
045	2	141T69-0	* MOTOR HOUSING COMPLETE	1	PC.
045	2	INC. 643653-8	* BRUSH HOLDER 6.5-13.5	2	PC.
046		266326-2	TAPPING SCREW 4X18	5	PC.
047		331719-3	PIPE 9	1	PC.
048		941201-0	FLAT WASHER 8	1	PC.
049		272253-3	LEVER 56	1	PC.
050		252199-9	HEX. NUT M8-13	1	PC.
051		257953-6	BOW STOP RING E-12	1	PC.
052	2	188448-7	* REAR COVER SET	1	PC.
052	2	INC.	* Item No. 54		
053		266326-2	TAPPING SCREW 4X18	2	PC.
054		819237-6	MAKITA LOGO LABEL	1	PC.
055		911268-2	PAN HEAD SCREW M5X45	3	PC.
056		862707-4	NAME PLATE F/5007MGA	1	PC.
057		419550-8	FRONT GRIP	1	PC.
058		643650-4	BRUSH HOLDER CAP 6.5-13.5	2	PC.
059	2	194986-9	CARBON BRUSH CB-154 2PC/SET W/ ORIGIN	1	SET
059	3	181047-4	CARBON BRUSH CB-154 2PCS/SET W/ ORIGIN	1	SET
060		257953-6	BOW STOP RING E-12	1	PC.
061		272253-3	LEVER 56	1	PC.
062		252199-9	HEX. NUT M8-13	1	PC.
063		941201-0	FLAT WASHER 8	1	PC.
064		345718-9	ANGULAR GUIDE	1	PC.
065	2	256511-5	SHOULDER PIN 6-7	1	PC.

Item No	Type	Part No	Description	Qty	Unit
066		257759-2	SLEEVE 6	1	PC.
067		941101-4	FLAT WASHER 5	1	PC.
068		922261-1	HEX. SOCKET HEAD BOLT M5X40	1	PC.
069		266396-1	FLAT HEADSQUARE NECKBOLT M8X24	1	PC.
070		331719-3	PIPE 9	1	PC.
071		345719-7	DEPTH GUIDE	1	PC.
072	2	256511-5	SHOULDER PIN 6-7 (Grove is added)	1	PC.
073		266237-1	CAP SQUARE NECK BOLT M8X90	1	PC.
074		266229-0	H.S.SET SCREW(CUP POINT)M5X8	1	PC.
075		158101-9	BASE COMPLETE	1	PC.
075	INC.	816846-2	SCALE PLATE	1	PC.
076		266229-0	H.S.SET SCREW(CUP POINT)M5X8	1	PC.
077		251370-2	+ PAN HEAD SCREW J5	1	PC.
078		419549-3	DIAL 27	1	PC.
079		216008-6	STEEL BALL 4	1	PC.
080		233314-4	COMPRESSION SPRING 4	1	PC.
081		266229-0	H.S.SET SCREW(CUP POINT)M5X8	1	PC.
082		251858-2	SCREW M6X15	1	PC.
083		253811-4	FLAT WASHER 5 (added)	1	PC.
084		253186-1	* FLAT WASHER 7	1	PC.
085	1	450351-5	* SPACER	2	PC.
A01		164095-8	GUIDE RULE	1	PC.
A02		783204-6	HEX. WRENCH 6	1	PC.
A03	2	A-94530-10	7-1/4" FRAMING BLADE, 24T 5/8" 10PC/PK	1	PC.
A03	Opt.	A-94839-10	7-1/4" FRAMING BLADE 24T, 10/PK	1	PC.
A04	1	824772-1	PLASTIC CARRYING CASE	1	PC.
A04	1	INC. 419360-3	HANDLE	1	PC.
A04	1	INC. 163455-1	LATCH	2	PC.
A04	2	158279-8	PLASTIC CARRYING CASE COM. (W/SPONGE)	1	PC.
A04	2	INC. 163455-1	LATCH	2	PC.
A04	2	INC. 419360-3	HANDLE	1	PC.
A05		804585-6	MODEL NO. LABEL	1	PC.
A06		199716-3	DUST NOZZLE SET	1	PC.
A06		INC. 272258-3	LEVER 37	1	PC.
A06		INC. 911223-4	PH SCREW M5X16 W/WR	1	PC.

SERVICE CHANGES: 5007MGA

1. Changes on Outer & Inner Flange

Item No.	Description	Type 1	Type 2
002	Outer Flange	224403-6	224409-4
003	Inner Flange	224151-7	224411-7

Above parts are completely interchangeable as a set.

2. Changes on Rear Cover Set, Spacer and Motor Housing Com.

(T/I#79802)

(T/I#DL830)

Item No.	Description	Type 1	Type 2	Type 3
52	Rear Cover Set	188178-0	188448-7	
85	Spacer	-----	450351-5	450351-5
45	Motor Housing Complete		158100-1	141T68-8

Above parts are completely interchangeable as a set.

Type 2 (T/I#79802)

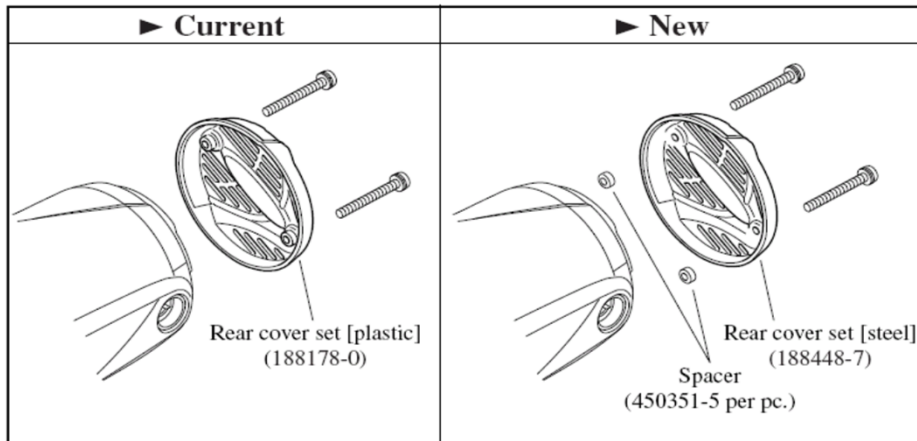

Type 3 (T/I#DL830)

Positioning portion of Motor housing completes has been added.

Part numbers of Motor housing completes remain the same.

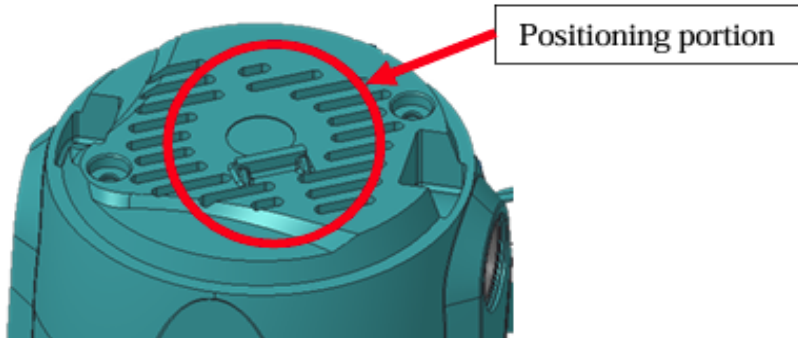

SERVICE CHANGES: 5007MGA

3. Changes on Flat Washer 7

Item No.	Description	Type 1	Type 2	Type 3
084	Flat Washer 7	-----	253186-1	-----

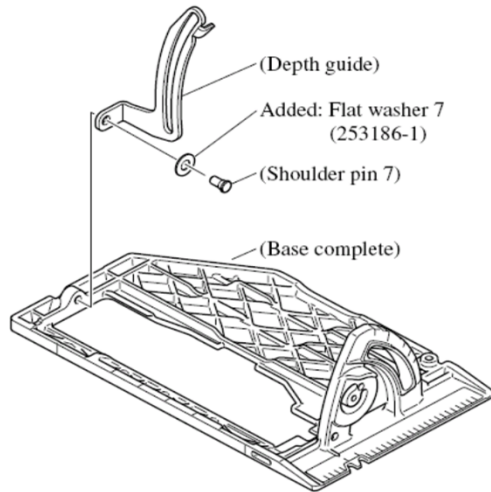

(Type 2 - Tech Info # 77294)

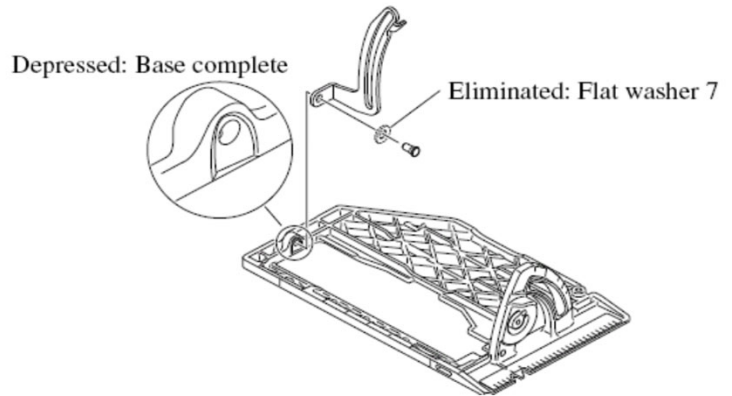

(Type 3 - Tech Info # 81095)

4. Changes on Switch

(T/I# 92740)

Item No.	Description	Type 1	Type 2
044	Switch	651190-8	651062-7

See T/I# 92740 for Wiring